

Heat exchangers made by THALETEC

POWERFUL & EFFICIENT

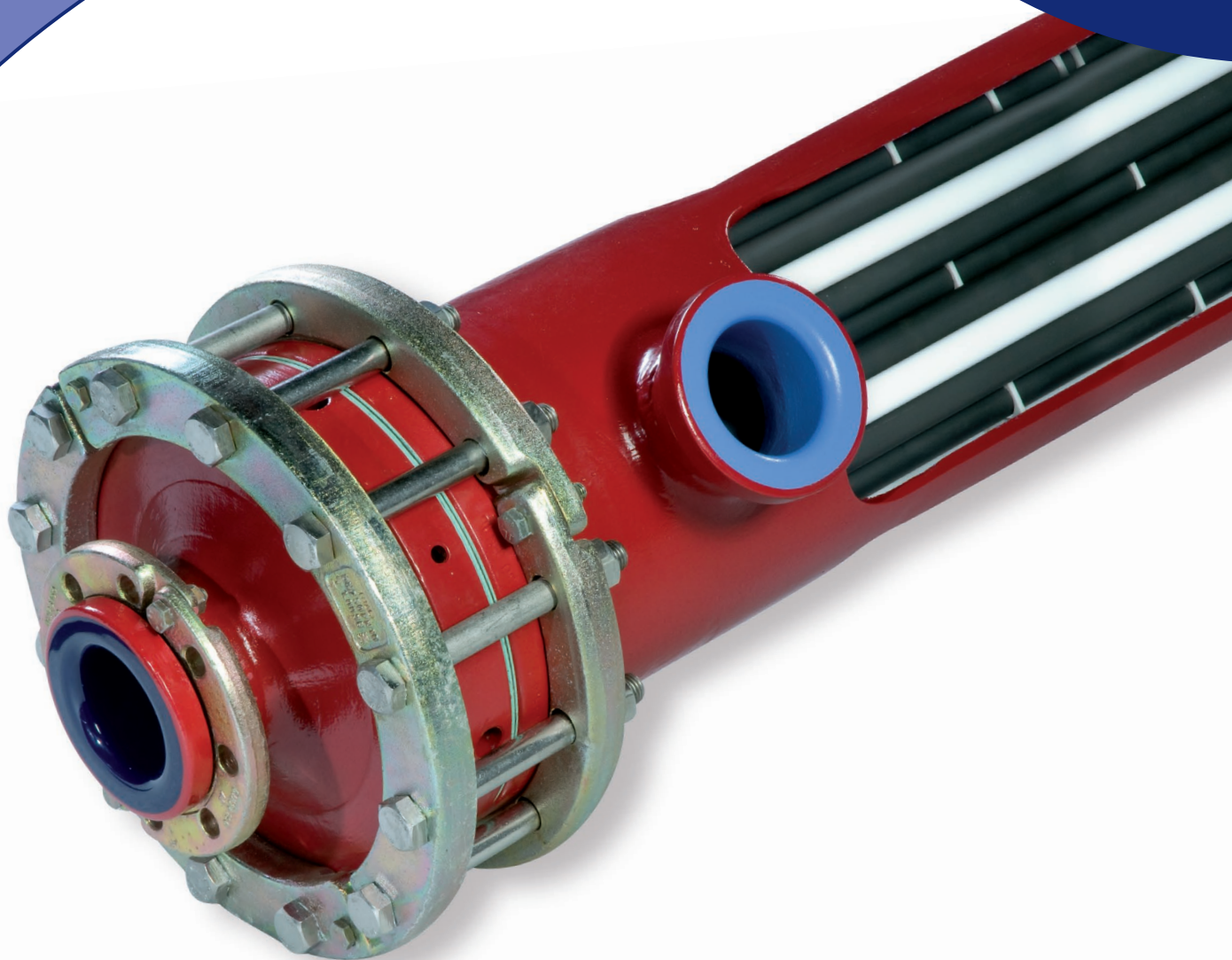

State-of-the-art heat exchanger technology

The state of the art summarizes what is technically feasible at a certain point of time. **THALETEC** has set the goal of providing state of the art heat exchanger technology.

Science is the production of new knowledge through research.

Systems that have been in use for many years are regularly examined for possible optimization in close cooperation with universities. One example is a study conducted by Martin-Luther University, Halle-Wittenberg. Through a scientific examination of a proven product, it was possible to perform a three-dimensional calculation of various geometric models using the finite element method (FEM) and to determine the optimum structural design of the U-tube/tubesheet system. The strain on this system could be reduced by 38%, and its operational reliability was significantly improved.

Efficient and effective heat transfer/ Energy efficiency and climate protection

With limited natural resources and a rise in energy costs plus our responsibility for the environment, we must take a systematic approach to improve the energy efficiency.

With its heat exchangers, **THALETEC** offers potential savings and optimization in the field of process heat recovery, a better utilization of the energy and material input, as well as a reduction of unnecessarily high thermal resistance.

In our factory, every single heat exchanger is individually rated and optimized for your process.

For many years, **THALETEC** has manufactured heat exchangers from glass lined U-tube bundles as well as compact heat exchangers comprising tubes made from silicon carbide.

We can offer you energy-efficient, intelligent solutions that have proven their worth in practice and rated by the **THALETEC process engineers using internally developed, proven software programs. Just give us a call, we will be pleased to assist you.**

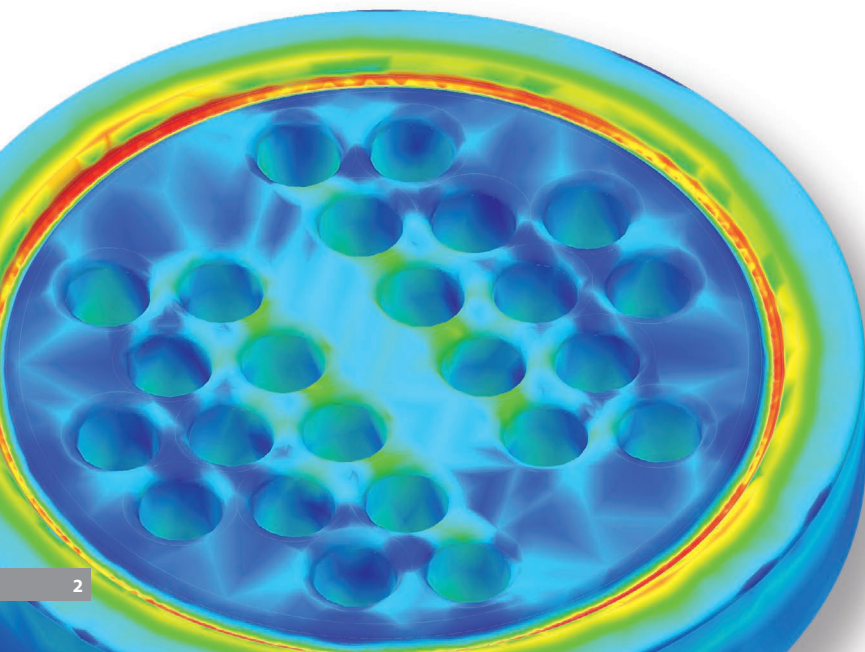
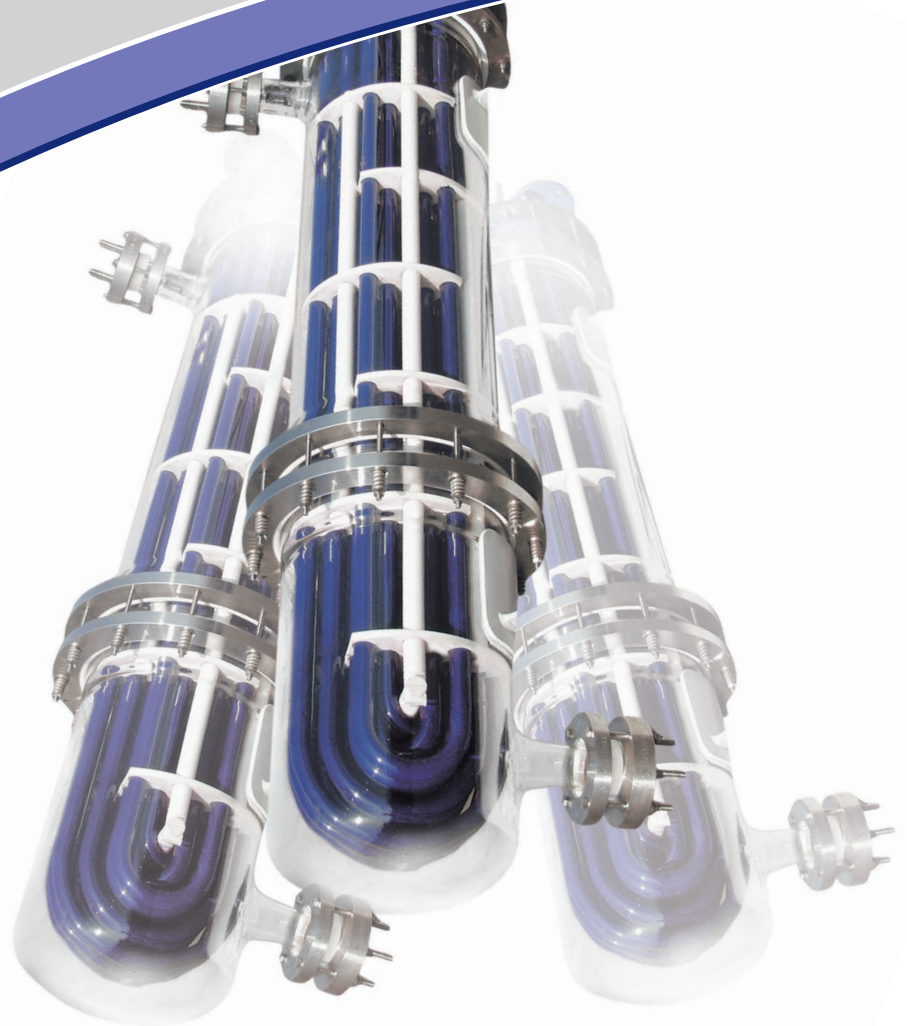

Finite Element Analysis (FEM) for determining the stress on the tube base in order to improve the operational reliability



Using a WTU Compact Heat Exchanger as a PowerBaffle
(see page 7 for details)

Overview of compact heat exchangers:

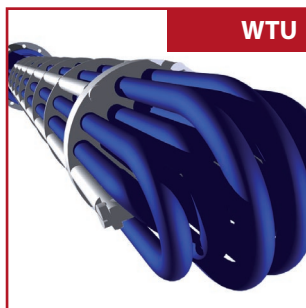

WTU

- Glass lined precision steel tube
- Tube base glass lined on product side
- Corrosive product around the tubes
- Tubes shrunk-in into glass lined tube base without gaskets

➔ see page 4 for details



WTS

- SIC-tube closed on one side
- Glass lined tube base
- Corrosive product around the tubes

➔ see page 8 for details



WTS-EA

- SIC-tube open on both sides
- Tube base glass lined on product side
- Corrosive product around the tubes

➔ see page 8 for details



WTS-EI

- SIC-tube open on both sides
- Tube base glass lined on product side
- Corrosive product inside the tubes

➔ see page 8 for details

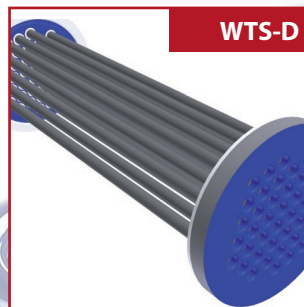

WTS-D

- SIC-tube open on both sides
- Tube base glass lined on both sides
- Corrosive exposure possible on both sides

➔ see page 8 for details

Glass lined U-tube bundle heat exchanger type WTU



Glass lined U-tube heat exchanger during assembly

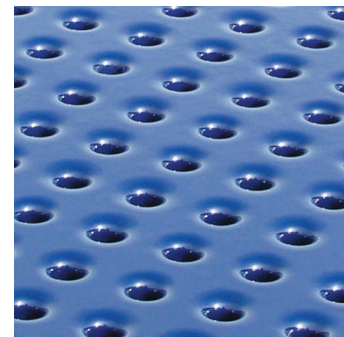

Glass lined bore plate. Top-quality tube/tubesheet connection.

Unique quality

Gasket-free glass lined U-tube bundle heat exchangers are a product from **THALETEC GmbH** which has proven its worth in industrial practice for more than a decade. Its mechanical design and production are unique worldwide.

Intelligent joining technology made by THALETEC

The two ends of the glass lined U-tube are machined to a precised diameter by a high-precision grinding process. The openings in the glass lined tube base are also mechanically machined to a defined diameter with a close tolerance. When the two components have been finished, the remaining glass layer thickness in the machined areas corresponds to the glass layer thickness on the remaining component, i.e. a homogeneous glass layer thickness is preserved on the whole surface of the components.

The glass lined U-tubes are installed in the glass lined tube base by generating a temperature difference of 160 K between the tube ends and the bottom hole. Both parts are fixed to each other by surface pressure.

GMP design

The glass lined U-tubes are fixed in the glass lined tube base without gaskets. This connection method reliably satisfies the requirements for GMP-compliant design. Product residues and impacts on the product are basically excluded due to the very concept.

This gasket-free connection between the tubes and the tube base is gas-tight and leakage-proof and satisfies even the highest demands on pressure resistance.

Thin glass layer makes things quite hot

Due to the relatively low thermal conductivity of glass, the U-tubes are coated with a layer thickness of 0.6 – 0.8 mm, and the glass coat is applied by an electrostatic process.

The process results in a homogeneous material structure with extremely low variation concerning the glass layer thickness. This ensures an even heat distribution and prevents thermal stress peaks in the glass layer.

Heat transfer with glass/steel

The diagram indicates the influence of the glass layer thickness on the heat transfer coefficient (K-value*). The heat transfer coefficient (K-value*) drops with increasing glass layer thickness, and the heat quantity that can be transferred is reduced accordingly.

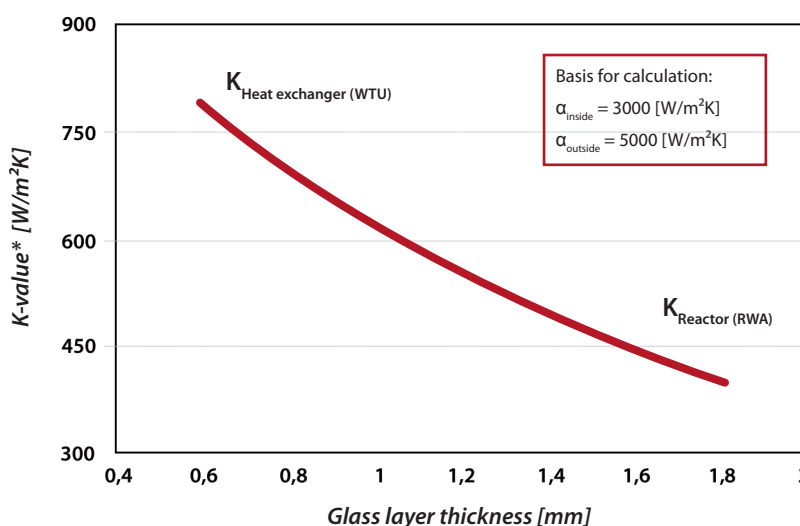

* equals the U-Value

Highest energy efficiency class

Due to their precision lining, the glass lined U-tube bundle heat exchangers made by **THALETEC** are capable of achieving a heat transfer coefficient of up to 800 W/m²K.

A comparison between the heat transfer coefficient of a glass lined reactor and a glass lined U-tube bundle heat exchanger reveals that the heat transfer coefficient (K-Value*) of the heat exchanger is three times higher than that of the reactor. That means that one square meter of heat exchanger surface corresponds to a comparable exchange surface of three square meters of a reactor, or that the heat exchanger's efficiency is 30% higher.

This comparison »only« accounts for the materials used, i.e. glass and steel. As a result, the 30% improvement of the heat transfer does not depend on the product or the fluid used on the service side.

The effective heat transfer surface of a reactor can be enlarged by up to 250% by using a glass lined tube bundle heat exchanger.

* equals the U-Value

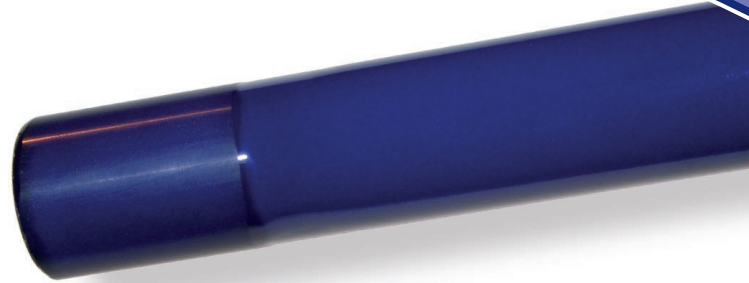

*Glass lined precision steel tube
25 mm * 2.6 mm in diameter
completely finished*

Application areas

Glass lined tube bundle heat exchangers are preferably used for condensation, evaporation and liquid-liquid heat exchange. The heat exchangers can be placed vertically, horizontally, or installed as a PowerBaffle inside a reactor.

Glass lined heat exchangers made by **THALETEC** have been approved under the German Water Management Act (WHG) and the Requirements concerning Flammable Liquids (VbF).

Design features

The standard operating pressure for **THALETEC** glass lined heat exchangers is -1 to +16 bars with an operating temperature of -60 to 220 degrees C.

Safety

All glass lined heat exchangers are subjected to a helium leakage test to verify their tightness. According to our experience, values ranging between 10⁻⁵ and 10⁻⁶ bar are reached. At the same time, the static friction between the tube and the tube base amounts to up to 20,000 N. The glass lined tubes can be strained up to their apparent yield point. As a result, they offer high operational reliability and protection against product contamination.

After-sales service

If necessary, the connection between the tube and the tube base can be released without any damages in order to replace individual tube segments.

THALETEC process engineering

We will be happy to perform free rating of your heat exchanger on request. Just fill in the questionnaire on page 11 and return it to us.

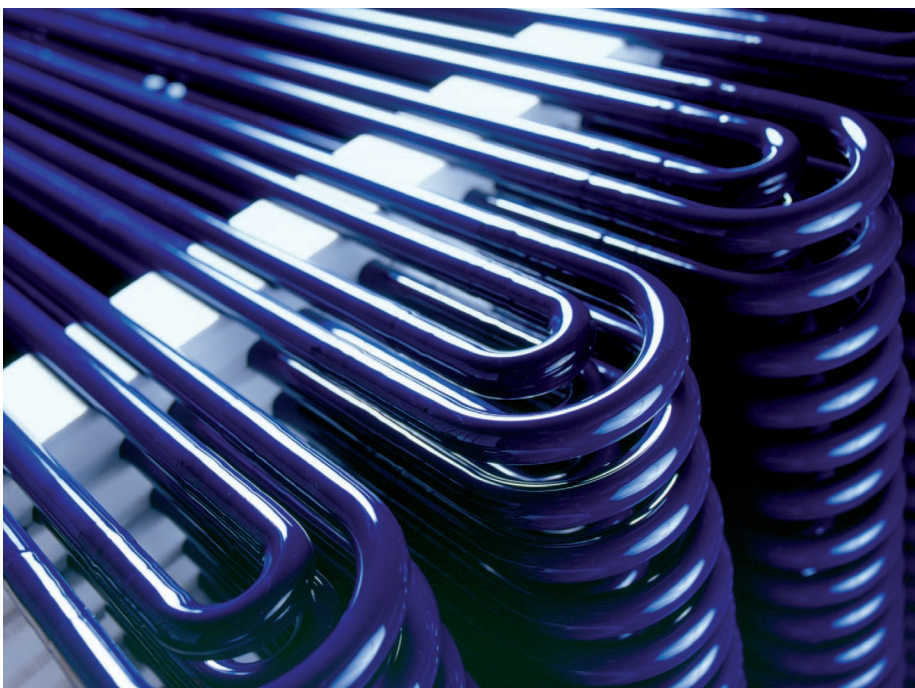

Glass-lined U-tube bundle heat exchangers WTU and PowerBaffle

Glass lined U-tube bundle heat exchanger installed in horizontal position

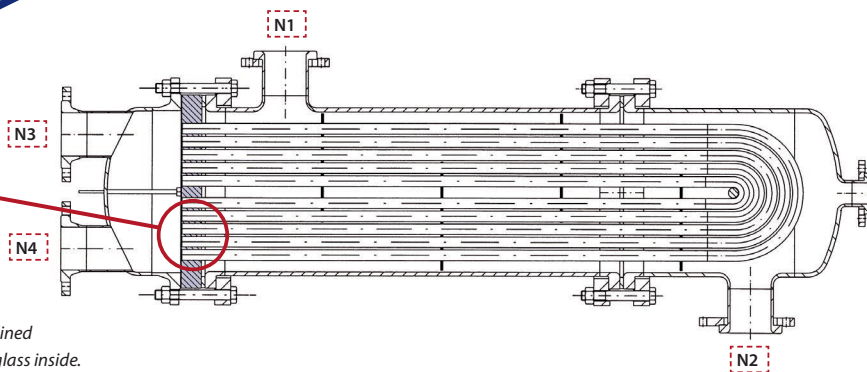
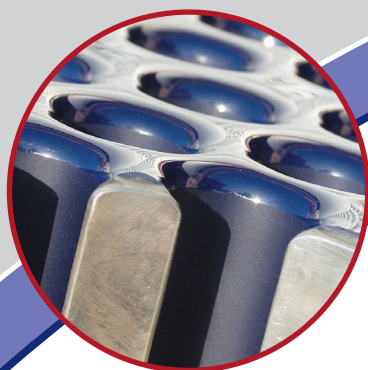

Cross-sectional view of a glass lined tubesheet note the machined glass inside. The gasket-free tube/tubesheet connection guarantees perfect fitting

Ordering example: WTU 250/2500-4,9

Nominal width DN	Heat exchange surface A [m ²]	Bundle length L [mm]	Total length L [mm]	Empty weight [kg]	Nozzle [DN]			
					Product side		Service side	
					N1*	N2	N3	N4
200	1,0	1000	1254	217				
	1,5	1500	1745	253				
	2,0	2000	2254	290				
	2,5	2500	2754	326				
	3,0	3000	3254	362	80	80	25	25
	3,5	3500	3754	400				
	4,0	4000	4254	436				
250	4,4	4500	4754	471				
	1,9	1000	1277	278				
	2,9	1500	1777	330				
	3,9	2000	2277	382				
	4,9	2500	2777	434	80	80	50	50
	5,9	3000	3277	488				
	6,9	3500	3777	540				
300	7,9	4000	4277	593				
	8,9	4500	4777	645				
	3,0	1000	1275	338				
	4,6	1500	1775	400				
	6,2	2000	2275	462				
	7,7	2500	2775	524	100	100	80	80
	9,3	3000	3275	588				
400	10,8	3500	3775	650				
	12,4	4000	4275	712				
	14,0	4500	4775	775				
	8,9	1500	1832	681				
	11,9	2000	2332	791				
	15,0	2500	2832	901	100	100	100	100
	18,0	3000	3332	1011				
500	21,1	3500	3832	1108				
	24,1	4000	4332	1230				
	27,2	4500	4832	1342				
	12,2	1500	1881	1048				
	16,4	2000	2381	1207				
	20,6	2500	2881	1365	150	150	100	100
	24,8	3000	3381	1524				
600	29,0	3500	3881	1685				
	33,2	4000	4381	1841				
	37,4	4500	4881	2000				
	17,4	1500	1921	1220				
	23,5	2000	2421	1430				
	29,6	2500	2921	1640	150	150	100	100
	35,6	3000	3421	1850				
600	41,7	3500	3921	2060				
	47,8	4000	4421	2270				
	53,9	4500	4921	2480				

* For condensers, the nominal width must be selected 2 sizes larger

**Use as baffle –
The THALETEC PowerBaffle**

The glass lined U-tubes making up a tube bundle are arranged very close to each other. This ensures narrow gaps, great turbulence and a high flow velocity around the tubes.

When installing the tube bundle inside a reactor, the U-tube bundle exposed to cross flow acts like a baffle. The broad cross-section of the tube bundle decelerates the fluid driven by the agitator and generates the baffling function - or change in flow direction - which is so important for the mixing process.

If desired, the THALETEC PowerBaffle can be equipped with the THALETEC temperature probe type »TS«. In this case, 2 PT100 are inserted into a glass lined tube. When the PowerBaffle is installed inside the reactor, the flow is directed at the temperature probe, and measurements are not influenced by the heated or cooled glass lined U-tubes.

The plugged-in PT100 can be easily removed for calibration. Thus, the PowerBaffle unites the function of a baffle, a temperature probe and a heat exchanger in a single component that occupies a SINGLE reactor nozzle only.

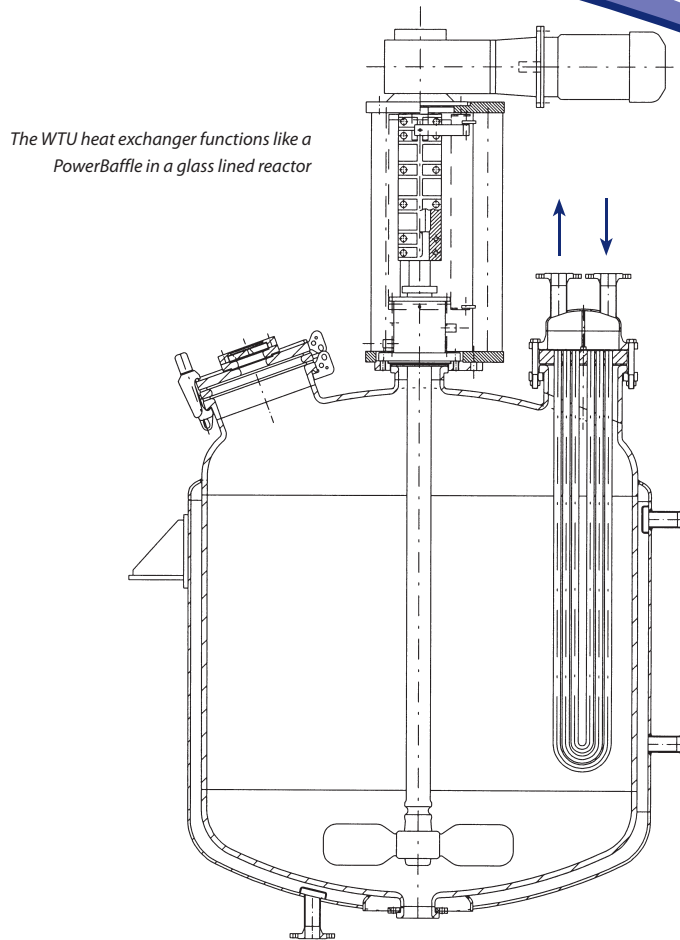

**Model calculation
for diagram on the right**

Heat exchange surface DIN reactor	29,5 m ²
Heat exchange surface 2 heater plugs	11,66 m ²
with regard to the K-value ratio of 3,06	35,68 m ²
effective total heat exchange surface	65,18 m²

Increasing the heat exchange surface

Increasing the **effective** heat exchange surface results in an optimized heat transfer, reduced heating and cooling times and lower energy cost.

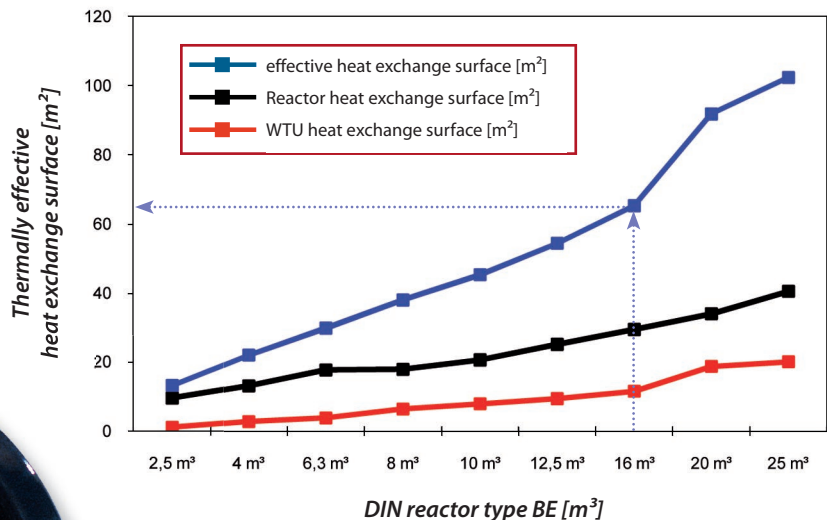

PowerBaffle inside a reactor

Glass lined compact heat exchangers with tubes made from silicon carbide (SiC)

As an alternate to glass lined tubes, **THALETEC** offers the option of silicon carbide tubes. With the SiC-tubes in a **THALETEC** heat exchanger, two corrosive fluids can be used in one heat exchanger – one fluid on the shell side and the other on the tube side.

The SiC compound heat exchangers close the gap between corrosive exposure on one side and on all sides. The known excellent corrosion properties of glass are combined with the equally high corrosion resistance of silicon carbide and its excellent thermal conductivity in these applications.

Intelligent joining technology made by **THALETEC**

In contrast to the gasket-free concept of the glass lined U-tube bundle heat exchanger, the SiC-tubes are sealed using two highly

Increasing the heat exchange surface

Thermal conductivity λ of competing materials [W/mK]

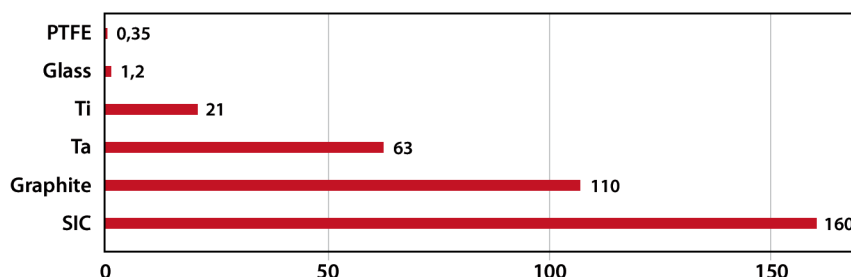

resistant O-rings made of perfluor elastomer material. On request, they are also available with FDA approval. The tube ends have been precision machined in the area of the tube base, and have been provided with grooves taking up the O-rings.

Safety through thick-walled SiC-tubes

In contrast to its competitors, **THALETEC** uses thick-walled SiC-tubes with a large cross-section. The thick-walled SiC-tubes offer higher mechanical stability and increased protection against damages to the tubes during cleaning processes. In addition, the large cross-section ensures cleaning ease and the operation of the heat exchanger with low pressure loss.

Safety through stress-free installation

The tubes are inserted without stress into the glass lined tube base(s). This kind of connection eliminates mechanical stress and tension of the SiC-tubes. Thermal apparatus stress is compensated by the gasket concept without being transferred to the tubes.

Efficient and effective heat transfer

The thermal conductivity of silicon carbide amounts to approx. 160 W/m²K, thus exceeding all comparable materials used in corrosive applications. Using the **THALETEC** compact heat exchangers, you can achieve heat transfer coefficients of up to 1,400 W/m²K.

Recovery of process heat

Both sides of the compact heat exchanger type WTS-D can be exposed to corrosive media, and the unit is especially suitable for the recovery of process heat. Hot, corrosive product that must be cooled down before being drawn off or further processed can be used to heat up another corrosive fluid.

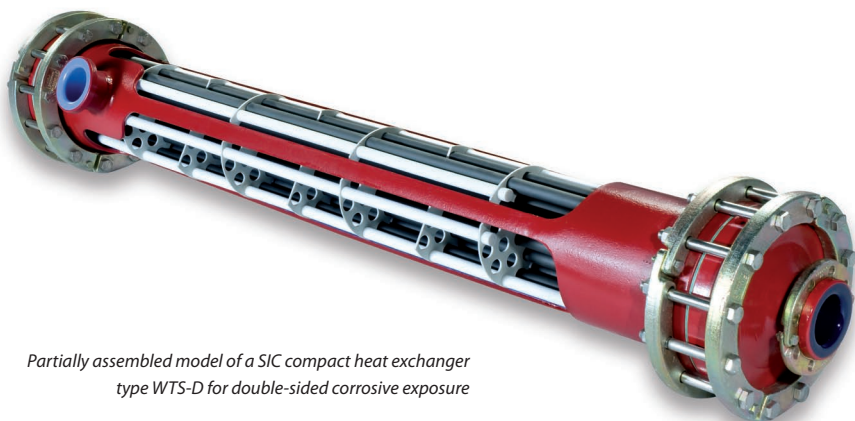

Partially assembled model of a SiC compact heat exchanger type WTS-D for double-sided corrosive exposure

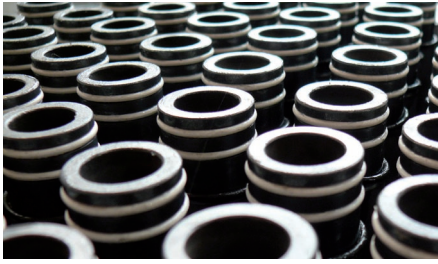

precision-machined SIC-tube ends with double O-ring seal

Application areas

Glass lined compact heat exchangers with SIC-tubes are preferably used for condensation, evaporation and liquid-liquid heat exchange. Both vertical and horizontal installation of the heat exchangers is possible.

The glass lined compact heat exchangers with SIC-tubes have been approved under the German Water Management Act (WHG) and the Requirements concerning Flammable Liquids (VbF).

Design features

In standard design, the glass lined compact heat exchangers with SIC-tubes are rated for an operating pressure of -1/+6 bar on the tube and jacket side. The permitted operating temperature of the standard component is -10 to 200 °C.

GMP design

All compact heat exchangers are suitable for GMP-compliant applications. FDA approvals can be submitted both for the O-rings used and for the silicon carbide tube material. On request, cleaning openings can be provided on the face and the cylindrical jacket tube of the apparatus.

Since the SIC-tubes are fixed on one side only and well sealed, the number of gaskets can be reduced by 50% for the heat exchanger type WTS.

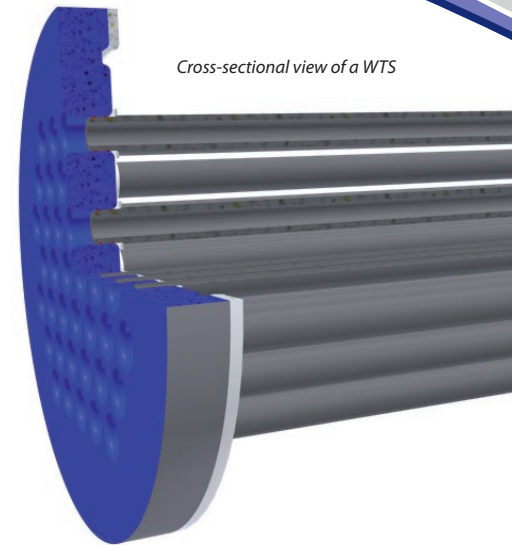

Cross-sectional view of a WTS

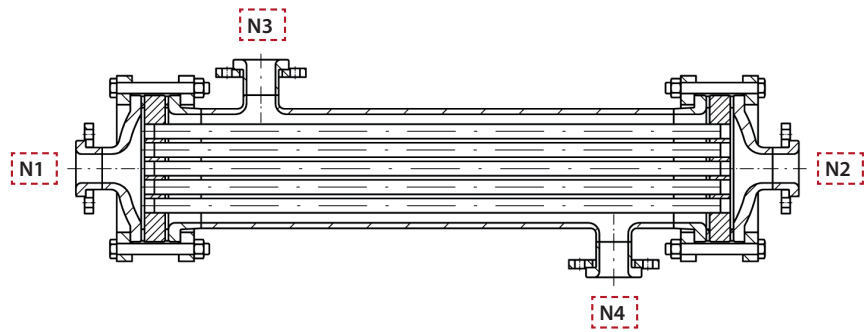

Ordering example: WTS-E(I) 250/2000-4,2

Nominal width DN	Heat exchange surface A [m ²]	Bundle length L [mm]	Total length L [mm]	Empty weight [kg]	Nozzle [DN]			
					N1	N2	N3*	N4
200	1,2	1000	1350	260				
	1,8	1500	1850	300				
	2,5	2000	2350	340	50	50	50	50
	3,1	2500	2850	380				
	3,7	3000	3350	420				
250	2,1	1000	1350	340				
	3,2	1500	1850	380				
	4,2	2000	2350	440	80	80	80	80
	5,3	2500	2850	490				
300	6,3	3000	3350	540				
	3,7	1000	1400	390				
	5,5	1500	1900	450				
	7,4	2000	2400	510	80	80	80	80
	9,2	2500	2900	570				
400	11,1	3000	3400	630				
	10,0	1500	1950	730				
	13,4	2000	2450	830	100	100	100	100
	16,7	2500	2950	930				
500	20,1	3000	3450	1030				
	14,4	1500	1960	1000				
	19,2	2000	2460	1140	150	150	100	100
	24,0	2500	2960	1290				
	28,8	3000	3460	1440				

* For condensers, the nominal width must be selected 2 sizes larger

Heat exchanger tubes for power plant, environmental and energy engineering

THALETEC GmbH developed glass lined tubes for a unique heat exchanger system that specially suits the needs of power plant, environmental and energy engineering.

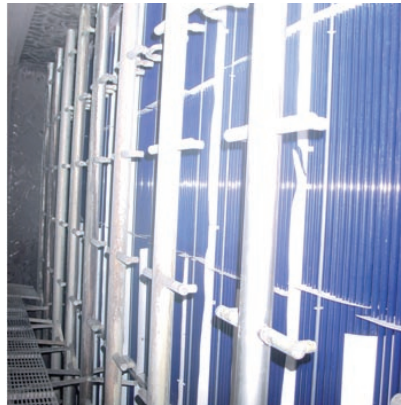

Inside the heat exchanger



Power plant, 3 blocks with a capacity of 500 MW each

In the beginning there was an idea

In order to satisfy the extreme demands of power plant engineering, a manufacturing line had to be developed first that enabled us to produce the desired length of glass lined heat exchanger tubes of 12 m.

For this purpose, THALETEC developed a special electrostatic coating method that is

also used for glassing the glass lined U-tubes for the WTU heat exchangers. This process results in a homogeneous material structure with extremely low variation concerning the glass layer thickness. This ensures an even heat distribution and prevents thermal stress peaks in the glass layer.

The glass lined heat exchanger tubes with a length of 12 m are assembled to form modules and then installed.

These modules are also used for flue gas desulphurization, incineration of household and hazardous waste, and for liquid-liquid heat exchange.

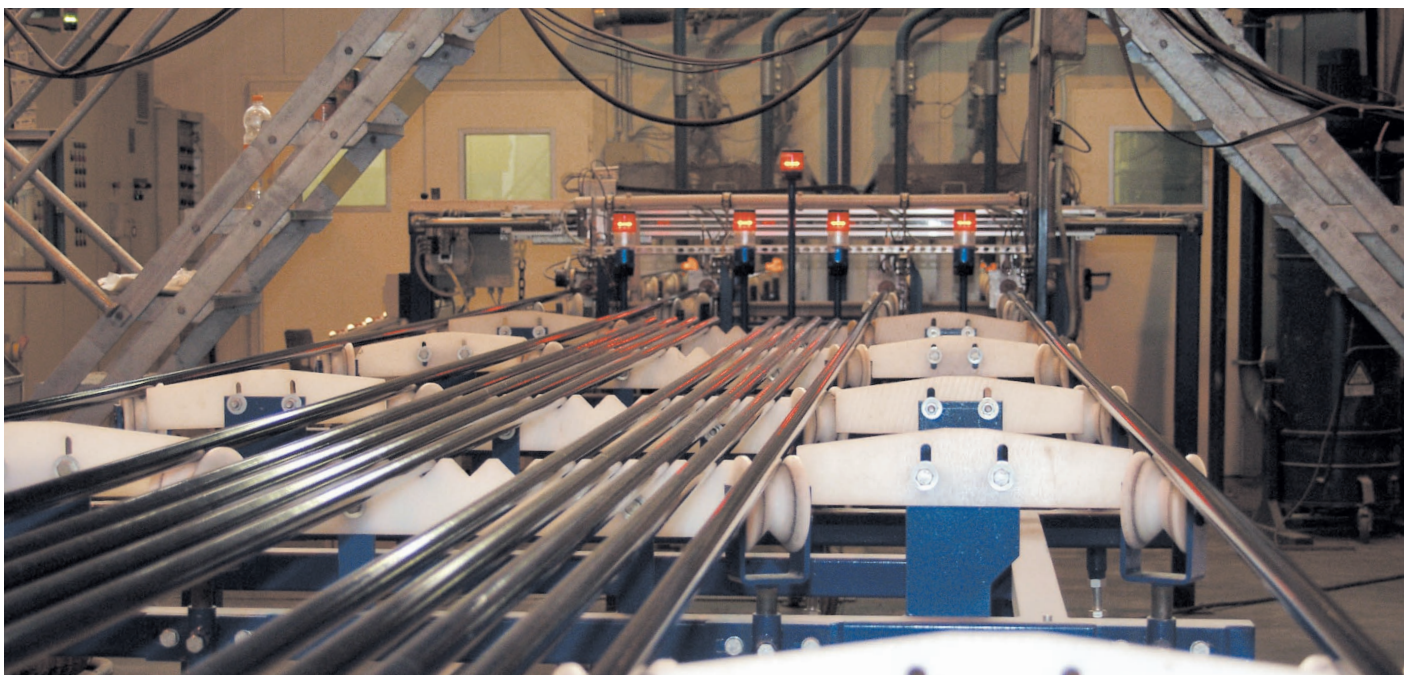

Fully automatic production line for manufacturing glass lined tubes using the dry electrostatic coating method

Process Questionnaire

Required for rating/optimizing new/existing heat exchangers

Company:

Name:

Department:

Telephone:

Facsimile:

Mobile phone:

E-mail address:

Your query/order:

THALETEC offer/order no.:

Heat exchanger type: WTU WTS WTS-EA WTS-EI WTS-D

Thermal task

Condensation (pure condensation) [yes/no]

Post-condensation [yes/no]

Condensate cooling [yes/no]

Cooling [yes/no]

Heating [yes/no]

Evaporation [yes/no]

Heat exchange liquid/liquid [yes/no]

Desired product flow

Inner tube [yes/no]

Outer tube [yes/no]

Temperatures:

	Product 1	Product 2
Inlet temperature	<input type="text"/> [°C]	<input type="text"/> [°C]
Outlet temperature	<input type="text"/> [°C]	<input type="text"/> [°C]

Material data:

	Gas phase	Liquid phase
Thermal conductivity	<input type="text"/> [W/mK]	<input type="text"/> [W/mK]
Density	<input type="text"/> [kg/m ³]	<input type="text"/> [kg/m ³]
Specific thermal capacity	<input type="text"/> [J/kgK]	<input type="text"/> [J/kgK]
Dynamic viscosity	<input type="text"/> [Pas]	<input type="text"/> [Pas]
Specific evaporation enthalpy	<input type="text"/> [KJ/kg]	<input type="text"/> [KJ/kg]
Fouling	<input type="text"/> [m ² /kW]	<input type="text"/> [m ² /kW]

Process data

	Product 1	Product 2 (heating/cooling medium)
Product name	<input type="text"/>	<input type="text"/>
Volume flow	<input type="text"/> [m ³ /h]	<input type="text"/> [m ³ /h]
Mass flow	<input type="text"/> [kg/h]	<input type="text"/> [kg/h]
Perm. pressure loss	<input type="text"/> [bar]	<input type="text"/> [bar]
Heat flux to be transferred	<input type="text"/> [KW]	

Apparatus data

Desired installation

horizontal

vertical

Supporting structure

horizontal

vertical

Insulation [yes/no]

Double jacket [yes/no]



Drawings and/or process descriptions are quite helpful for rating your system. Please send us this information together with the completed questionnaire, if available. Thank you very much for your cooperation!

Please fill in the questionnaire and send it to: process@thaletec.com • Fax: +49 (0) 3947 778 130

We would like to advise you regarding the advantages of glass lined equipment like:

- Glass lined reactors acc. to DIN 28136
- Glass lined Pharma Reactors
- Components for pharmaceutical and high purity applications
- Mixing technology for pharmaceutical and chemical industry
- Reactors for Polymerization
- Storage Tanks and Receivers
- Columns
- Heat Exchangers
- Sensor technology
- Accessories

www.thaletec.com

THALETEC all around service

24-h-Hotline:
+ 49 (0) 171 68 44 254

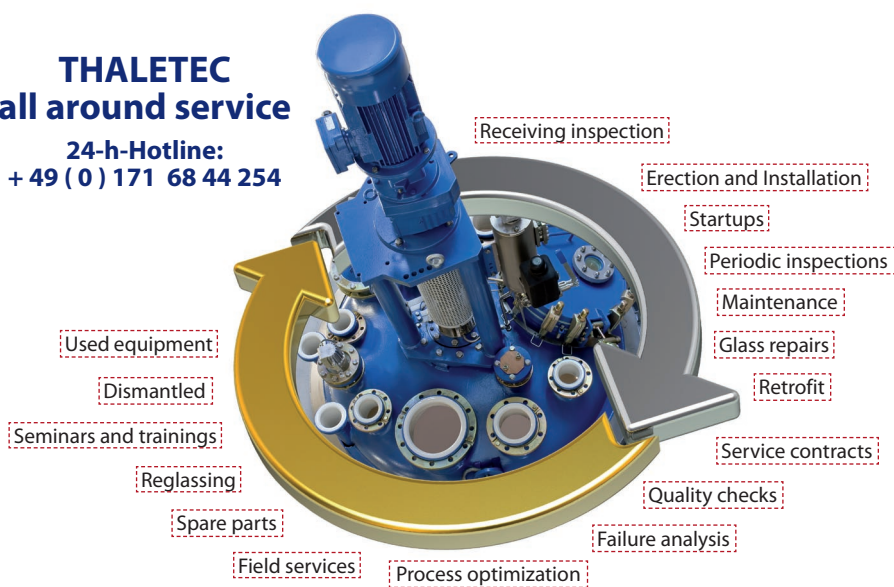

THALETEC GmbH

Steinbachstraße 3
D - 06502 Thale

Telephone:
+ 49 (0) 3947-778 0
Facsimile:
+ 49 (0) 3947 778 110

service@thaletec.com
www.thaletec.com

